

# INSULATED BI-FOLD DOOR BUILT IN HEADER MOUNT

EXAMPLE DRAWING

(NOT TO SCALE)

FOR REFERENCE ONLY - TRUSS SUPPLIER TO SIZE HEADER &  
TRUSS TO SUPPORT THE WEIGHT OF THE BI-FOLD DOOR

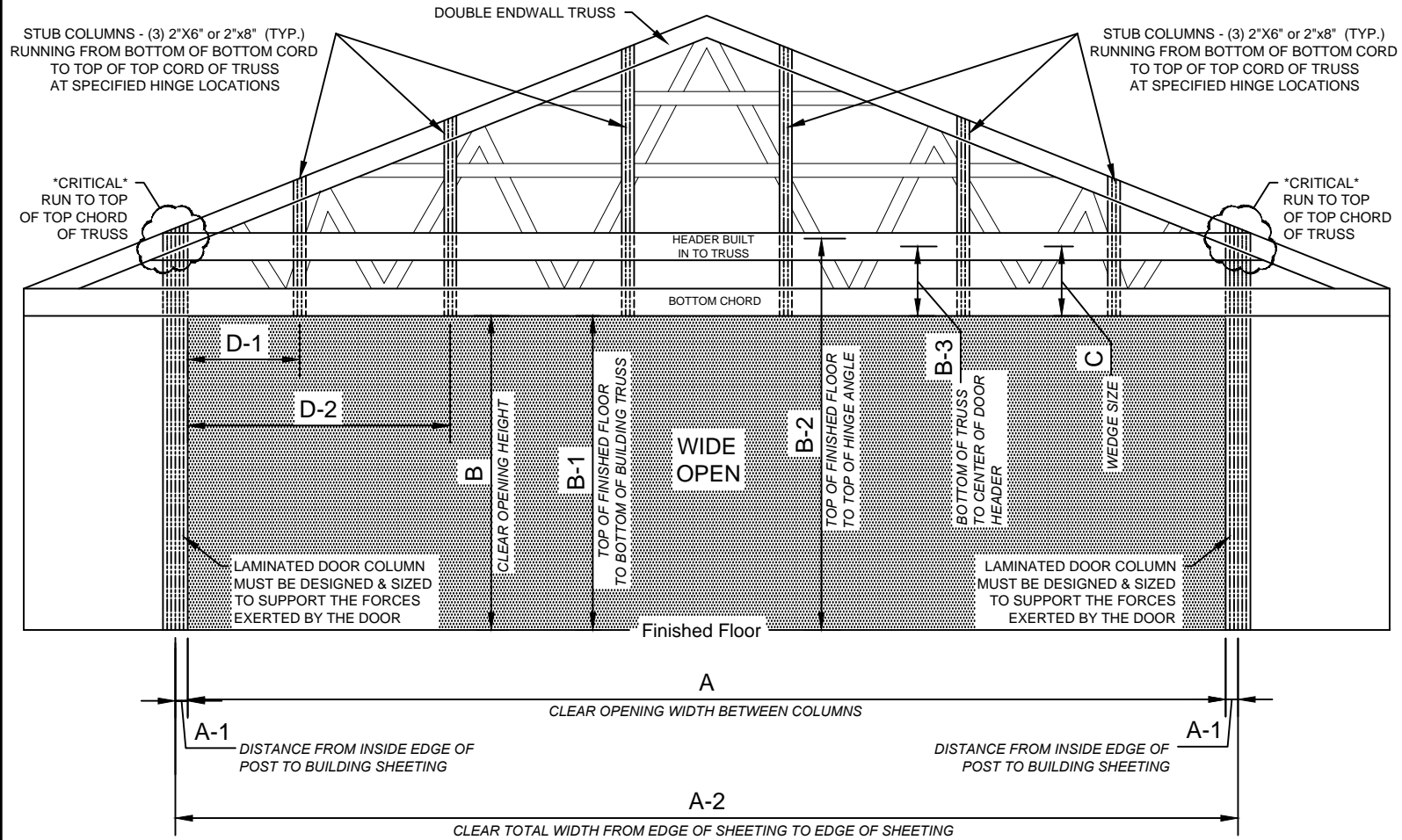

DRAWING  
NUMBER  
**IB1**

PHONE :  
1-800-921-7008  
FAX:  
701-277-8961

MIDLAND DOOR SOLUTIONS  
1021 7th Street NE  
WEST FARGO, ND 58078



# BUILT IN HEADER TOP VIEW

NOT TO SCALE

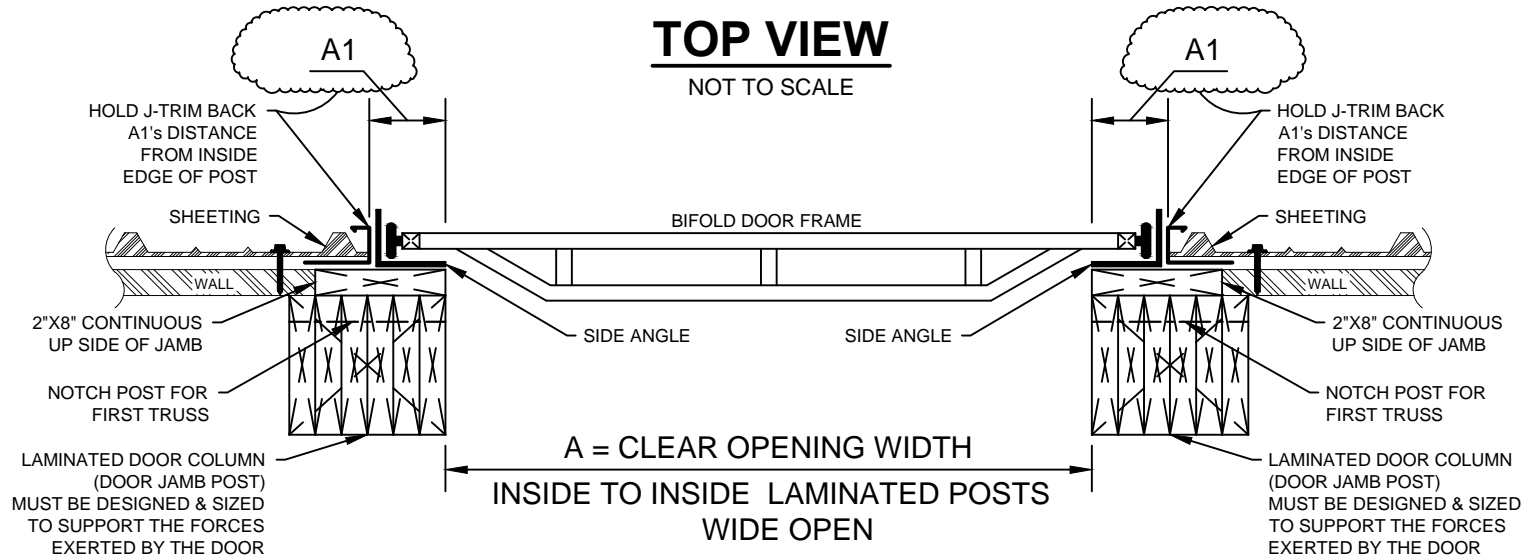

DRAWING NUMBER  
**IB2**

PHONE : 1-800-921-7008  
FAX: 701-277-8961

MIDLAND DOOR SOLUTIONS  
1021 7th Street NE  
WEST FARGO, ND 58078

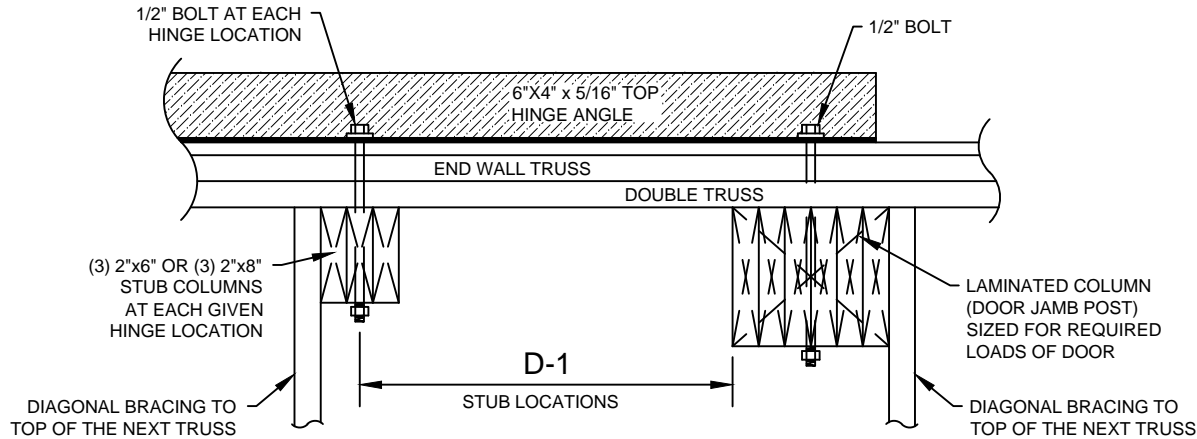

# BUILT IN HEADER HINGE DETAIL - TOP VIEW

NOT TO SCALE



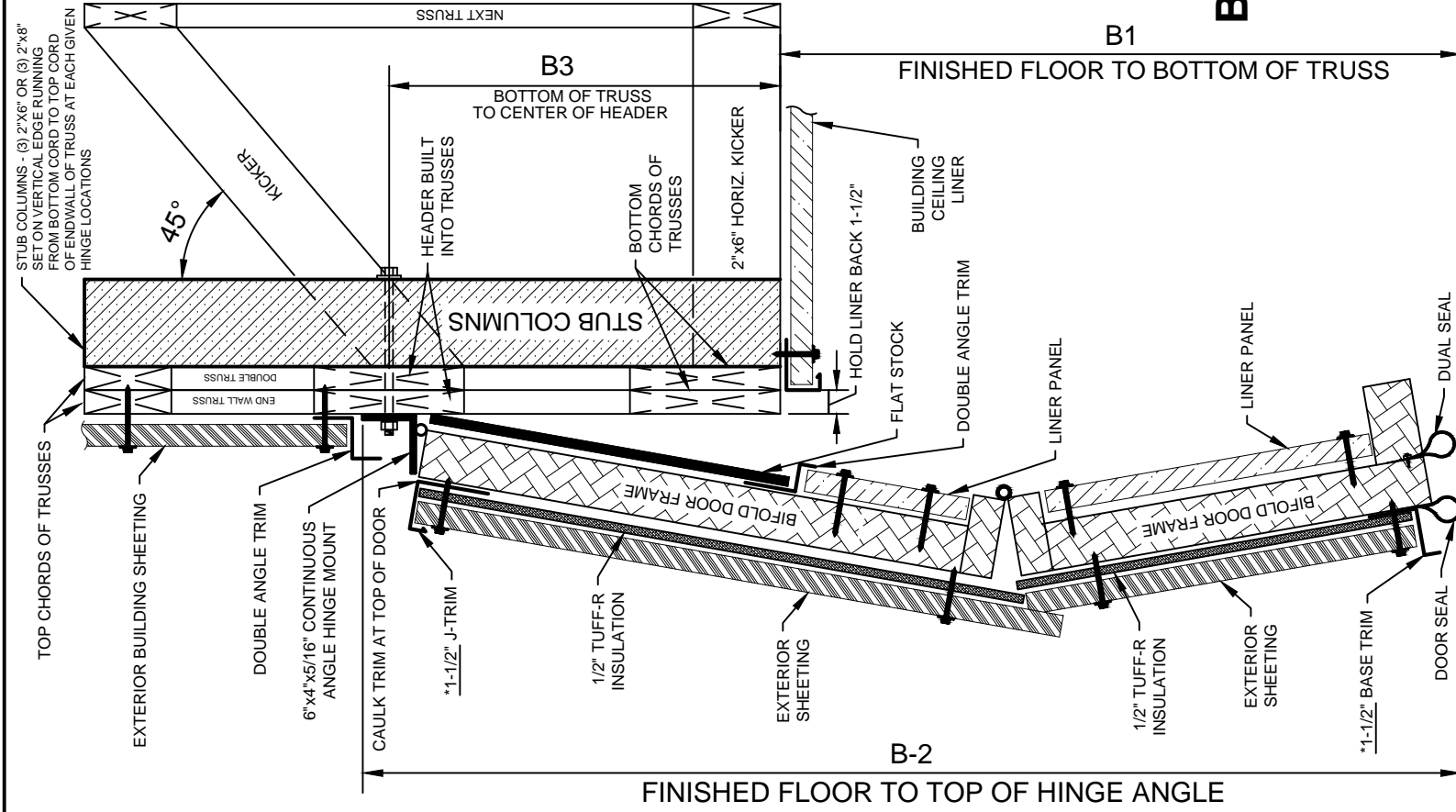
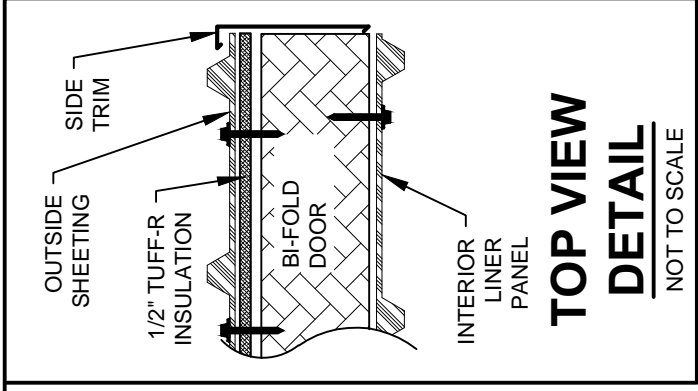

DRAWING NUMBER  
**IB3**

PHONE :  
1-800-921-7008  
FAX:  
701-277-8961

MIDLAND DOOR SOLUTIONS  
1021 7th Street NE  
WEST FARGO, ND 58078

